MT GRAVATT LAPIDARY

SOCIETY INC

55th Annual Gem and Mineral Display 2023
SATURDAY 27th MAY 8.00 am - 4.00pm
AT OUR CLUBROOMS 1873 LOGAN RD UPPER MT. GRAVATT 4122

2023 SCHEDULE

NOTES AND CONDITIONS

Each entry will not be judged against its competitors but will be assessed against an established standard and the resulting score is the measurement of excellence achieved, or how nearly it reaches that standard.

Judging is to Competitor and Judging Manual issue No.8 April 2015, available in the library. The competition committee will be using the guidelines as set out in the Competitor and Judging Manual issue No.8 April 2015 expect as stated in this schedule.

COMPETITION ENTRY IS FREE

Closing date for entries SECTIONS 1 TO 27 is Saturday 22nd April 2023

Entries accepted at the clubrooms from 2pm to 5 pm or by arrangement with the Chief Steward

Closing date for SECTIONS 28 TO 39 is Wednesday 24th May 2023

Entries accepted at the clubrooms between 6pm – 8pm or by arrangement with the Chief Steward

Postal entries should be sent by registered mail to:

Chief Steward

PO Box 150

MT GRAVATT QLD 4122

PLEASE ENSURE YOU INCLUDE RETURN POSTAGE AND AN APPROPRIATE SIZED ENVELOPE

- No change will be made to the schedule once approved
- No late entries will be accepted
- Entries can be collected from 4.15 P.M. SATURDAY 27th May 2023
- **Please note** if you cannot collect your entries then you **MUST** make arrangements with the Chief Steward
-
- This is a Level Two Competition. Interstate entries are welcomed. **OTHER CLUBS ARE WELCOME.**
- Entries not complying with conditions may be disqualified by Stewards, or placed in the correct section. The Stewards have the right to refuse any entry.
- All possible care will be taken with entries, but the Committee will not be held responsible for loss or damage during transit, display or storage.
- An entry constitutes acceptance of conditions and agreement to comply with them.
- Unsportsmanlike conduct displayed before, during or after the competition may result in disqualification of the entry and the revocation of any awards given. Page 5 AFLACA Judges and Competitor's Manual No. 8 April 2015.

Variations to Competitor and Judging Manual

1. Class No's do not correspond with Section No's in the J&R Manual
2. A pair of earrings or cufflinks are judged as one item (Jewellery Sections only)
3. Limit of 3 entries per person per class
4. Showcase entry quantities vary from the manual
5. Man-made material can be used as specified in the schedule
6. All Metalcraft with sharp or pointed elements must have all sharp/pointed edges padded and be presented in a rigid box ready for postage. This is a requirement of Australia Post and must be met so that entries can be sent for judging. Stewards can refuse entries if packaging requirements are not met.

ENQUIRIES TO: Phone 3219 3381 or Email: show@mglslapidary.com.au

MT GRAVATT LAPIDARY SOCIETY INC. – 55th Annual Gem and Mineral Display 2023

C=Craftsmanship, AA=Aesthetic Appeal, Min=minimum, Max=maximum, J & R=Judging and Rules Manual

| Class No. | | J&R Section | Page No. | AA or C |
|---------------|--|-------------|----------|---------|
| NOVICE | | | | |
| 1 | PRESIDENTS CUP – Mt Gravatt Members only Standard cabochon; any material; min 22mm on the longest axis | 1A | 24 | AA |
| 2 | Standard cabochon; material petrified wood; min 22mm on the longest axis | 1A | 24 | C |
| 3 | Fancy cabochon; material Agate , min 30mm on the longest axis | 1B | 27 | AA |
| 4 | Freeform; any natural material ; max 50mm longest axis; must not pass through a 15mm hole | 3 | 32 | C |
| 5 | Flamewalker, Material Quartz; min 6mm; Diagram attached | 10 | 51 | |
| 6 | Standard Brilliant ,Faceted girdle; Any Natural Quartz; min 8mm: Design Attached | 8B | 45 | |
| 7 | Commercial Mount Jewellery; with lapidary cut & set by entrant; material any natural; min 22mm on the longest Axis | 25 | 78 | |
| 8 | Jewellery Hand-Fabricated; not intended to include lapidary, fossil or mineral items | 18A | 72 | |
| 9 | Jewellery Hand-Fabricated; lapidary cut and set by entrant | 18B | 73 | |
| 10 | Jewellery Hand-Fabricated; with commercial lapidary item/s set by entrant; glass beads allowed | 18D | 75 | |
| OPEN | | | | |
| 11 | The MEMORIAL TROPHY (Previously the ARTHUR MULLENS) Mt Gravatt members only Fancy cabochon; Any Natural Material; set shape (template in the workroom) | 1B | 27 | C |
| 12 | Standard cabochon; material Banded Agate; min 22mm on the longest axis | 1A | 24 | AA |
| 13 | Standard Cabochon; material any natural; min 22mm on the longest axis | 1A | 24 | C |
| 14 | Fancy cabochon; material Obsidian; max 75mm on the longest axis; Two or more inside curves | 1B | 27 | AA |
| 15 | Freeform; Any Natural material; max 85mm on the longest axis; must not pass through a 15mm hole | 3 | 32 | C |
| 16 | Cabochon with Crystal cavity; max 50mm on longest axis. NB the cavity cannot be more than 50% of the cabochon; Material Quartz . Judging sheet available from MGLS. | | | |
| 17 | Standard Brilliant ,Faceted girdle; Any Natural Quartz; min 8mm: Design Attached | 8B | 45 | |
| 18 | Lilium – Marco Voltalini ; material Quartz ; min 6mm; Design attached | 11 | 53 | |
| 19 | Jewellery Hand-Fabricated; not intended to include lapidary, fossil or mineral items | 18A | 72 | |
| 20 | Jewellery Hand-Fabricated; lapidary cut and set by entrant | 18B | 73 | |
| 21 | Jewellery Hand-Fabricated; commercial lapidary item/s set by entrant | 18D | 75 | |
| 22 | Jewellery Hand-Fabricated; natural mineral item/s set by entrant | 18C | 74 | |
| 23 | Jewellery Hand-Fabricated; to include crystal cavity cabochon cut and set by entrant. | 18B | 73 | |
| 24 | Jewellery Combined; with commercial lapidary set by entrant, may include Pearls; must include cast elements from patterns, moulds or dies (eg. cuttlefish casting); Patterns, moulds or dies must be made by the entrant. Cast elements must be 20% or more of the design. | 23D | 72 | |
| 25 | Jewellery Combined; with natural mineral item/s set by entrant; must include natural cast elements (eg. water casting, broom casting). Cast elements must be 20% or more of the design. | 23D | 72 | |
| 26 | General Metalcraft; not intended to included lapidary; Metalcraft is defined as items that are for general ornamentation and/or service, not jewellery; size to measure between 10mm to 170mm on the longest axis | 27A | 83 | |

MT GRAVATT LAPIDARY SOCIETY INC. – 55th Annual Gem and Mineral Display 2023

| | | | | |
|---|---|------------------------|-----------------|----------------|
| 27 | General Metalcraft; with Commercial lapidary set by entrant; Metalcraft is defined as items that are for general ornamentation and/or service, not jewellery; size to measure between 10mm to 170mm on the longest axis | 27B | 84 | |
| Class No. | | J&R Section | Page No. | AA or C |
| NOVELTY GEMCRAFT OPEN | | | | |
| 28 | Novelty Gemcraft; material predominantly lapidary; Entries must be accompanied by a label stating title and main materials (Label will not be judged) | 17 | 62 | C |
| CARVING OPEN | | | | |
| 29 | Carving three dimensional; hardness under 4; Entries must be accompanied by a label stating title and main materials | 5A | 38 | |
| 30 | Carving three dimensional; hardness 4 & over; Entries must be accompanied by a label stating title and main materials | 5A | 38 | |
| NOVELTY - Open to everyone and will not be judged, the judges will make a choice | | | | |
| 31 | Picture stone, picture to be named, rough or polished | Judges Choice | | |
| 32 | FOSSICKERS CUP Best entry found on a club field trip between - 1 st June 2019 and 1 st May 2020 | Judges Choice | | |
| SHOWCASES NOVICE | | | | |
| 33 | Showcase; Solo; unlit; 5 cabochons and/or freeform stones; at least 3 different shapes and 4 different materials | 30A | 95 | |
| 34 | Showcase; Solo; unlit; 5 pieces of handcrafted jewellery | 30A | 95 | |
| 35 | Showcase; Solo; unlit; 3 faceted stones in a small box; any shape or material | 30A | 95 | |
| SHOWCASES OPEN | | | | |
| 36 | Showcase; Solo; unlit; 9 cabochons and/or freeform stones; at least 3 different shapes and 4 different materials | 30A | 95 | |
| 37 | Showcase; Solo; unlit; 7 pieces of handcrafted jewellery; at least one with and one without lapidary material | 30A | 95 | |
| 38 | Showcase; Solo; unlit; 5 faceted stones in a small box; any shape or material | 30A | 95 | |
| 39 | Showcase; Solo; unlit; 8 mineral specimens; all specimens must be miniature size or larger | 35A | 120 | |

Please note – Showcase items must be labeled. See J&R manual page 88 for information

- Exhibitors please note that there are some showcases available for loan from the stewards

Section 5: Flamewalker

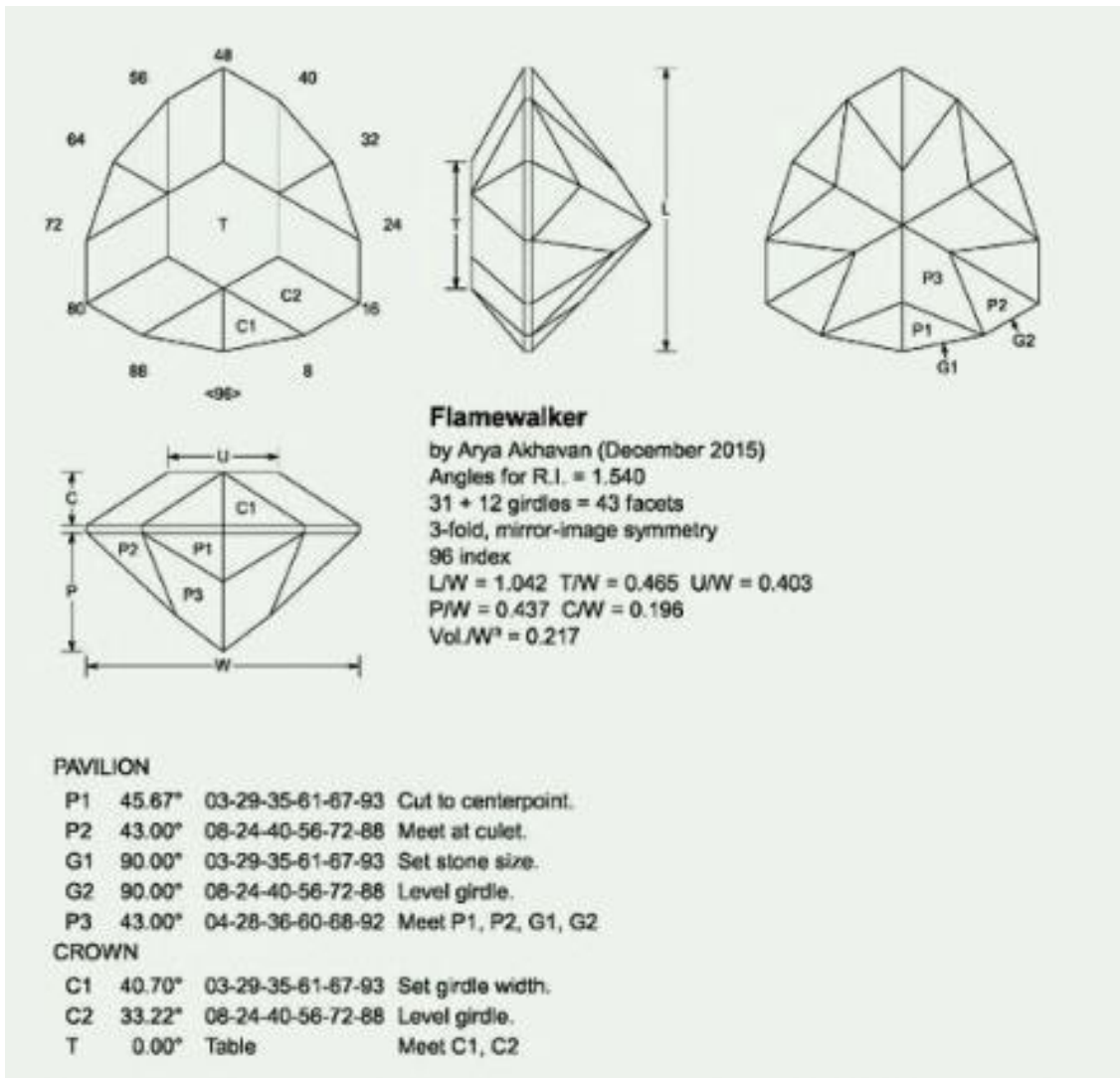

Section 18: Liliu-Marco Voltolini

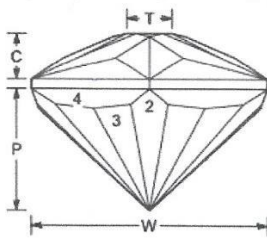
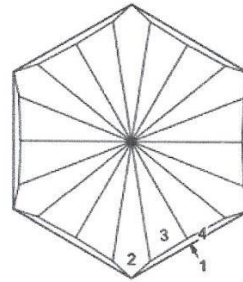
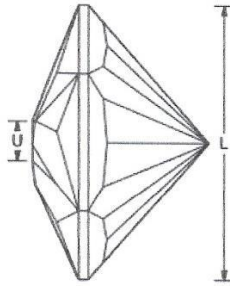
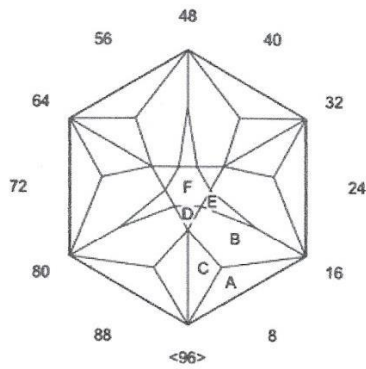

Liliu

Marco Voltolini

Angles for R.I. = 1.540

49 + 6 girdles = 55 facets

3-fold, mirror-image symmetry

96 index

L/W = 1.155 T/W = 0.191 U/W = 0.165

P/W = 0.511 C/W = 0.196

Vol./W³ = 0.281

PAVILION

| | | | |
|---|--------|-------------------------------------|--------------------|
| 1 | 90.00° | 08-24-40-56-72-88 | set stone size |
| 2 | 41.50° | 96-16-32-48-64-80 | Set centerpoint |
| 3 | 42.50° | 07-09-23-25-39-41-55-57-71-73-87-89 | Cut to centerpoint |
| 4 | 70.00° | 08-24-40-56-72-88 | Level girdle |

CROWN

| | | | |
|---|--------|-------------------|----------------------|
| A | 34.00° | 08-24-40-56-72-88 | Set girdle thickness |
| B | 22.90° | 12-20-44-52-76-84 | Meet girdle |
| C | 25.28° | 04-28-36-60-68-92 | " |
| D | 7.27° | 96-32-64 | Meet C |
| E | 21.35° | 16-48-80 | No meets |
| F | 0.00° | Table | |

Angles for quartz (and higher RI's)

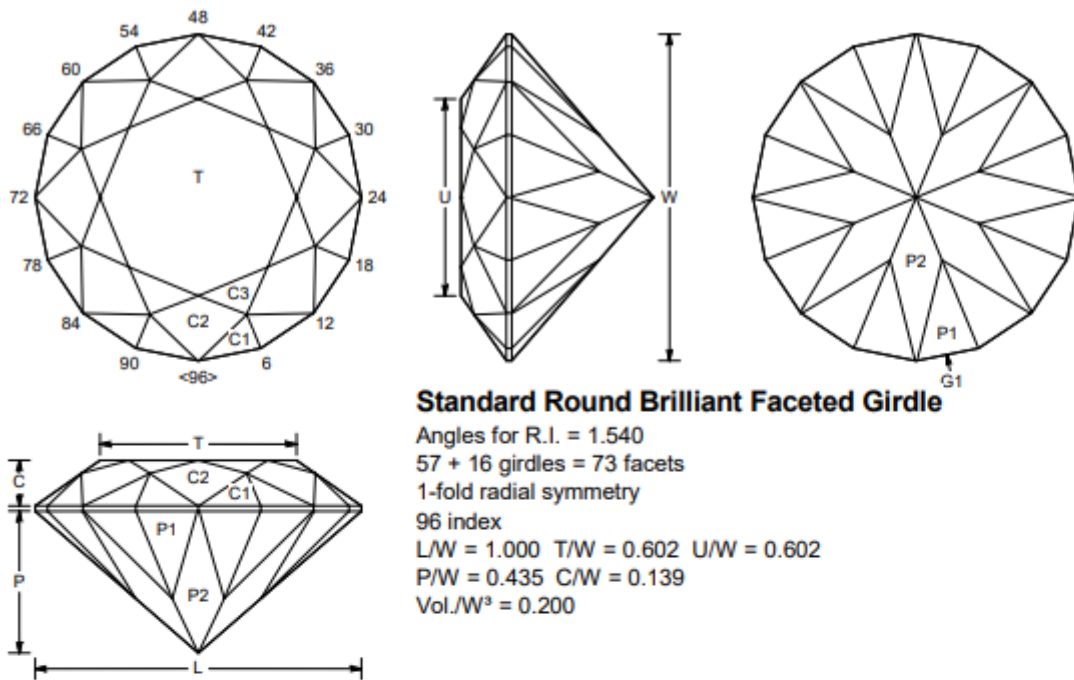

Standard Round Brilliant Faceted Girdle

Angles for R.I. = 1.540
 57 + 16 girdles = 73 facets
 1-fold radial symmetry
 96 index
 $L/W = 1.000$ $T/W = 0.602$ $U/W = 0.602$
 $P/W = 0.435$ $C/W = 0.139$
 $Vol./W^3 = 0.200$

PAVILION

| | | | |
|----|--------|---|------------------|
| P1 | 43.00° | 03-09-15-21- 27-33-39-45- 51-57-63-69- 75-81-87-93 | Cut to TCP |
| G1 | 90.00° | 03-09-15-21- 27-33-39-45- 51-57-63-69- 75-81-87-93 | Outline Girdle |
| P2 | 41.00° | 96-12-24-36- 48-60-72-84 | Cut to meet C1-G |

CROWN

| | | | |
|----|--------|---|----------------------|
| C1 | 42.00° | 03-09-15-21- 27-33-39-45- 51-57-63-69- 75-81-87-93 | Set Girdle Thickness |
| C2 | 35.00° | 96-12-24-36- 48-60-72-84 | Cut to meet C1-G |
| C3 | 20.00° | 06-18-30-42- 54-66-78-90 | Cut to meet C1-C2 |
| T | 0.00° | Table | Cut to meet C3-C2 |

D:\My Docs\Gem Show\Standard Round Brilliant Faceted Girdle.gem

Trophies & Cups

- **Presidents Cup** – MGLS members only
Awarded for the highest scoring entry in section 1
- **The Memorial Trophy** (Previously the **Arthur Mullens**)– MGLS members only
Awarded for the highest scoring entry in section 10
- **Don Wilkinson Trophy**
Awarded to the entry that scores the highest number of judging points for an individual open freeform, sections 4, 14 & 15.
- **Laurie & Val Saint Trophy**
Awarded to the entry that scores the highest number of judging points for an individual novice silver piece.
- **Lionel Whitby Memorial Trophy**
Awarded to the entry that scores the highest number of judging points for an individual open novelty gemcraft entry, section 29.
- **Fossicker’s Cup**
Awarded for the best entry found on a field trip see section 33 (Judges Choice)
- **Best in Show**
Awarded to the single entry that scores the highest number of judging points in an individual section (excluding showcases)
- **Show Champion**
Show Champion is determined by the highest accumulated points scored by an individual.
Points accrued as follows:
Best in Show 5pts
1st place 5pts
2nd place 4pts
3rd place 3pts
Highly Commended 2pts
Judges Choice 1pts

Please Note:

- **Fossicker’s Cup**
Entries must be entered as found however entries can be partially slabbed but must not be worked.

